

Slide bracket

Type M16 (pitch 1.0)

SMA Series



Slide bracket A-2
(Stroke=9)

Slide bracket A-2
(Stroke=15)



Slide bracket A-2
(Stroke=20)

Slide bracket A-2
(Stroke=25)

Slide bracket A-2
(Stroke=30)

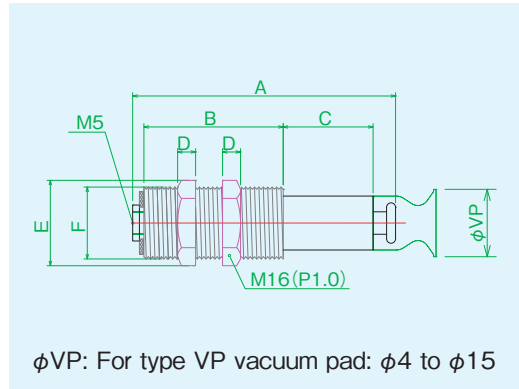

ϕVP : For type VP vacuum pad: $\phi 4$ to $\phi 15$

*Vacuum pads are sold separately. (p.20 - 21)
*Pipe fittings are not equipped. (See p. 45)

Product name		Slide bracket A-2 (Stroke=9)	Slide bracket A-2 (Stroke=15)	Slide bracket A-2 (Stroke=20)	Slide bracket A-2 (Stroke=25)	Slide bracket A-2 (Stroke=30)
Part code		*SMA-2	*SMA-2-15	*SMA-2-20	*SMA-2-25	*SMA-2-30
Dimensions	A	36.5	48.5	58.5	68.5	78.5
	B	20	26	31	36	41
	C	9	15	20	25	30
	D	4	4	4	4	4
	E	21.8	21.8	21.8	21.8	21.8
	F	M16 (P1.0)	M16 (P1.0)	M16 (P1.0)	M16 (P1.0)	M16 (P1.0)
Weight		16g	18g	20.2g	22.2g	24.2g
Material		POM	POM	POM	POM	POM



Slide bracket A-1
(Stroke=9)

Slide bracket A-1
(Stroke=15)



Slide bracket A-1
(Stroke=20)

Slide bracket A-1
(Stroke=25)

Slide bracket A-1
(Stroke=30)

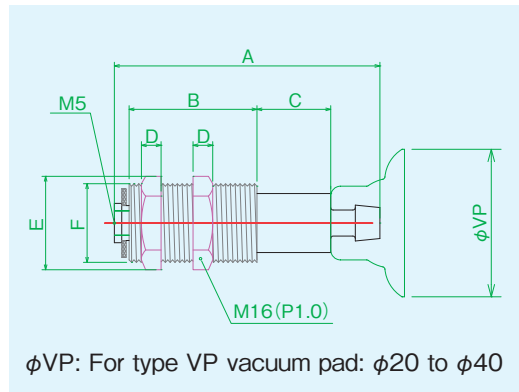

ϕVP : For type VP vacuum pad: $\phi 20$ to $\phi 40$

*Vacuum pads are sold separately. (p.20 - 21)
*Pipe fittings are not equipped. (See p. 45)

Product name		Slide bracket A-1 (Stroke=10)	Slide bracket A-1 (Stroke=15)	Slide bracket A-1 (Stroke=20)	Slide bracket A-1 (Stroke=25)	Slide bracket A-1 (Stroke=30)
Part code		*SMA-1	*SMA-1-15	*SMA-1-20	*SMA-1-25	*SMA-1-30
Dimensions	A	42	54	64	74	84
	B	20	26	31	36	41
	C	9	15	20	25	30
	D	4	4	4	4	4
	E	21.8	21.8	21.8	21.8	21.8
	F	M16 (P1.0)	M16 (P1.0)	M16 (P1.0)	M16 (P1.0)	M16 (P1.0)
Weight		16g	18.4g	20.3g	22.5g	24.6g
Material		POM	POM	POM	POM	POM

Slide bracket

SMC and SMD type

Slide bracket C-1
(ST=10)



Slide bracket C-2
(ST=10)



Product name	Slide bracket C-1 (ST=10)	Slide bracket C-2 (ST=10)
Part code	*SMC-1	*SMC-2
Weight	25g	25g

Slide bracket C-1
(ST=10)

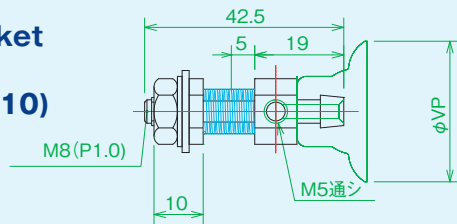

φVP: For type VP vacuum pad: φ20 to φ40

*Vacuum pads are sold separately. (p.20 - 21)
*Pipe fittings are not equipped. (See p. 45)

Slide bracket C-2
(ST=10)

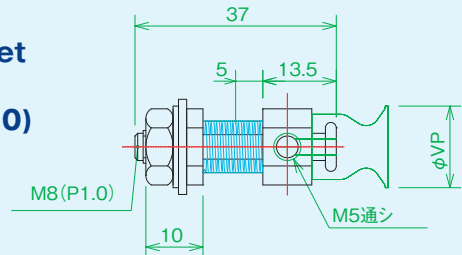

φVP: For type VP vacuum pad: φ4 to φ15

*Vacuum pads are sold separately. (p.20 - 21)
*Pipe fittings are not equipped. (See p. 45)

Fixing bracket D-1



Fixing bracket D-2



Product name	Fixing bracket D-1	Fixing bracket D-2
Part code	*SMD-1	*SMD-2
Weight	11g	11g

Fixing bracket D-1

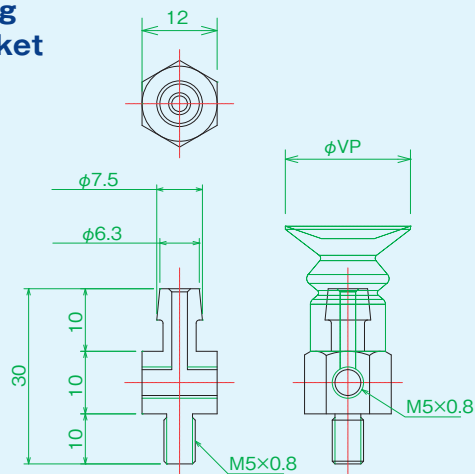

φVP: For type VP vacuum pad: φ20 to φ40

*Vacuum pads are sold separately. (p.20 - 21)
*Pipe fittings are not equipped. (See p. 45)

Fixing bracket D-2

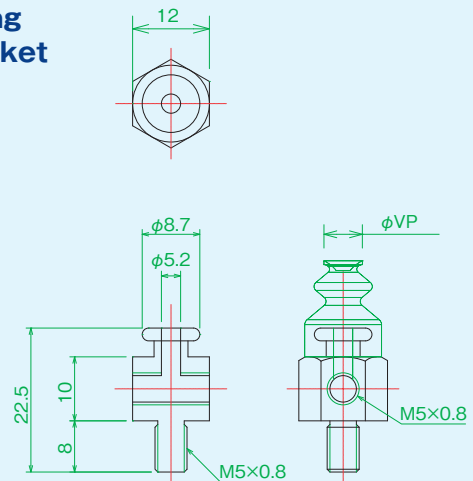

φVP: For type VP vacuum pad: φ4 to φ15

*Vacuum pads are sold separately. (p.20 - 21)
*Pipe fittings are not equipped. (See p. 45)

Angle adjustment bracket

Accessories

SMA-1: for SMA-2

Angle adjustment bracket L Assy



Angle adjustment bracket S Assy



Product name	Angle adjustment bracket L Assy	Angle adjustment bracket S Assy
Part code	SMA9000	SMA9001
Weight	71g	66g
Material	SPCC	SPCC

(Usage example)

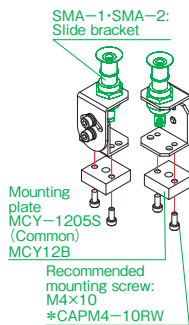
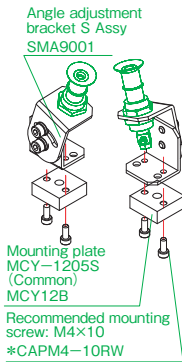

Angle adjustment bracket L Assy

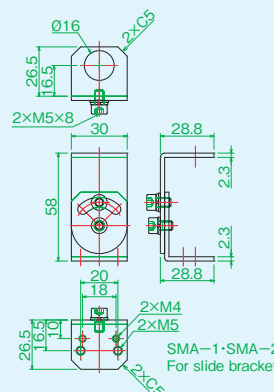

Angle adjustment bracket S Assy

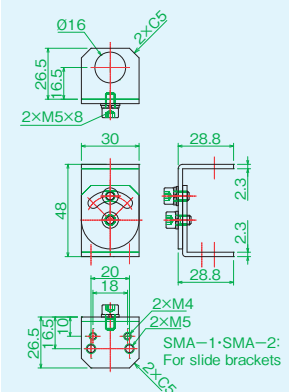

Accessories

MCY-1205S mount plate

MCY-1205S mount plate



Product name	MCY-1205S mount plate
Part code	MCY12B
Weight	16g
Material	A5052P

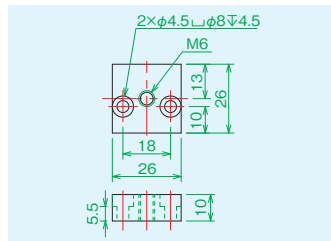

(Usage example)

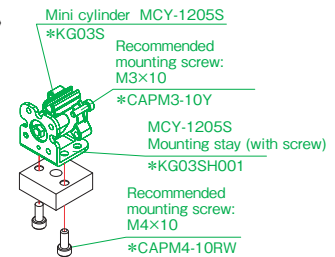

Accessories

SMAKB : SMAKL : SMAKS

Angle adjustment bracket B for SMA



Angle adjustment bracket L for SMA



Angle adjustment bracket S for SMA



Product name	Angle adjustment bracket B for SMA	Angle adjustment bracket L for SMA	Angle adjustment bracket S for SMA
Part code	SMAKB	SMAKL	SMAKS
Weight	30g	34g	29g
Material	SPCC	SPCC	SPCC

(Usage example)

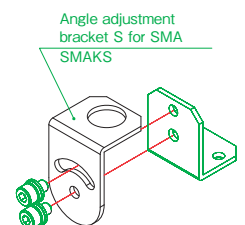
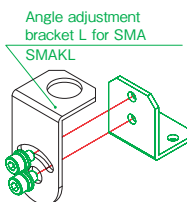
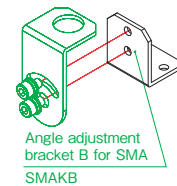

Angle adjustment bracket B for SMA

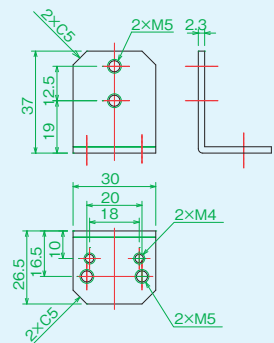

Angle adjustment bracket L for SMA

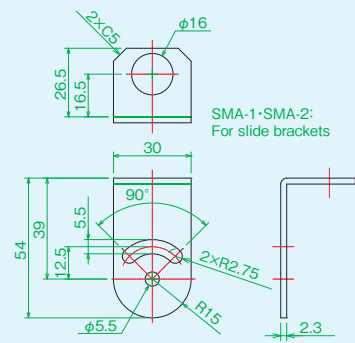

Angle adjustment bracket S for SMA

