

Slide rail

Accessories

Type A

Slide rail A6 (L=220) *For attachment holder A5•A6

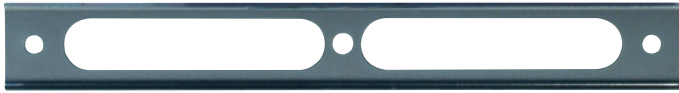

Product name	Slide rail A6 (L=220)
Part code	SLDRA6
Weight	50g
Material	SPCC

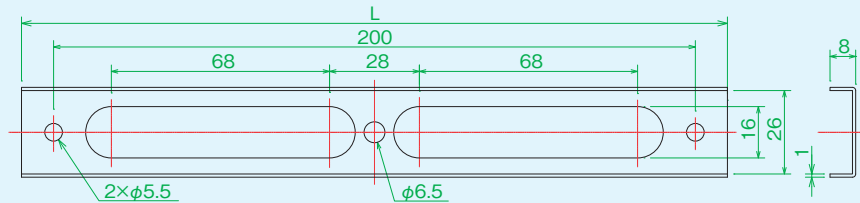

Slide rail A7 (L=280) *For attachment holder A7



Product name	Slide rail A7 (L=280)
Part code	SLDRA7
Weight	61g
Material	SPCC

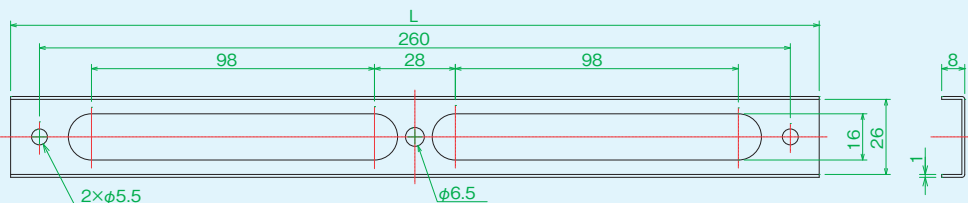

Accessories

Type B

Slide rail B6 (L=220) *For attachment holder A5•A6



Product name	Slide rail B6 (L=220)
Part code	SLDRB6
Weight	54g
Material	SPCC

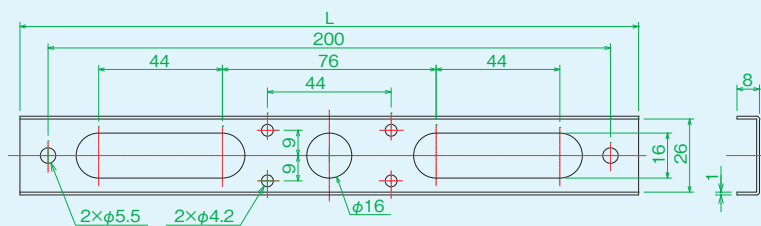

Slide rail B7 (L=280) *For attachment holder A7



Product name	Slide rail B7 (L=280)
Part code	SLDRB7
Weight	65g
Material	SPCC

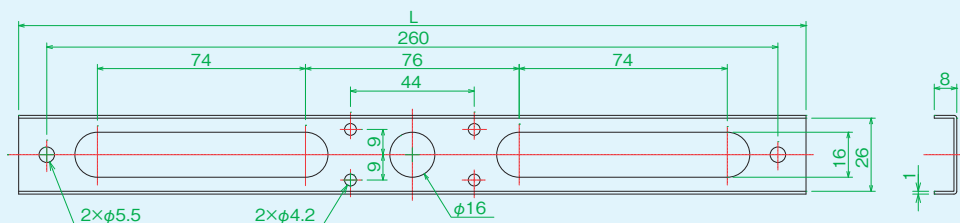

Slide rail

Accessories

Type C

Slide rail C



Product name	Slide rail C1 (L=100)	Slide rail C2 (L=200)	Slide rail C3 (L=300)
Part code	SLDRC1	SLDRC2	SLDRC3
Weight	43g	86g	129g
Material	SS400	SS400	SS400

Product name	Slide rail C4 (L=400)	Slide rail C5 (L=500)	Slide rail C10 (L=1000)
Part code	SLDRC4	SLDRC5	SLDRC10
Weight	172g	215g	430g
Material	SS400	SS400	SS400

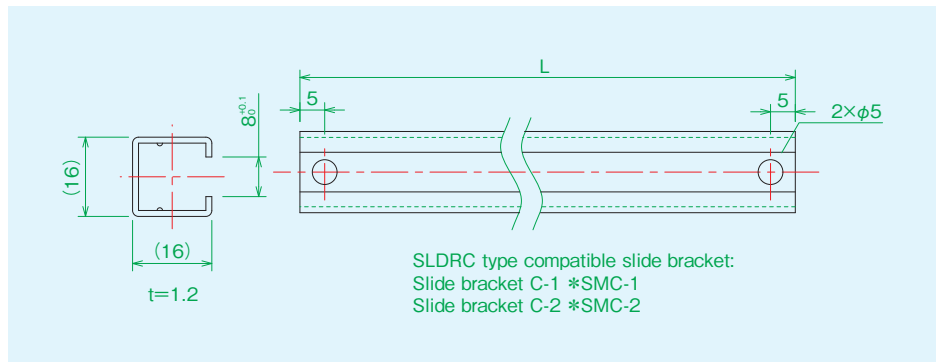

(Usage example)

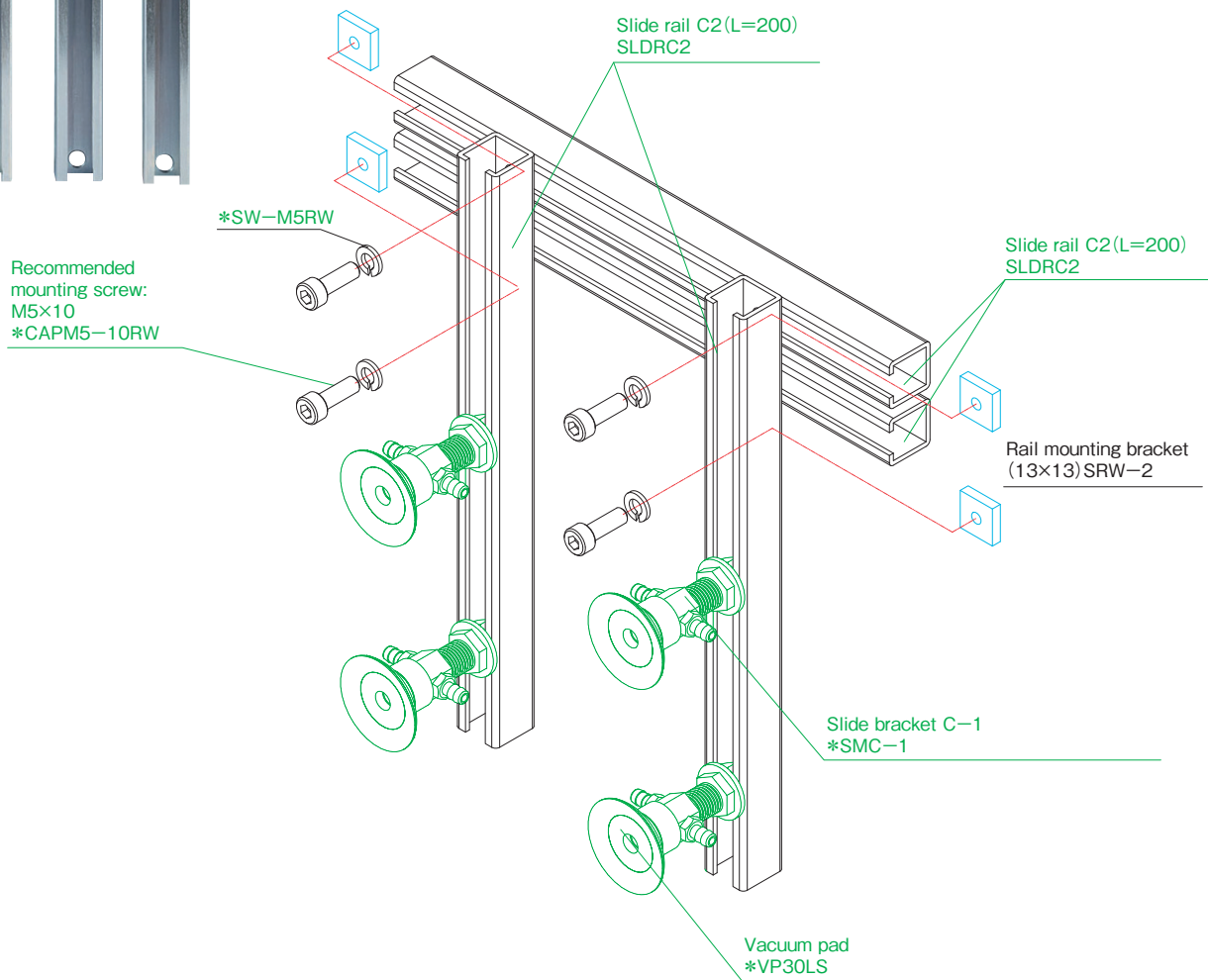

Slide rail

Accessories

Type D

Slide rail D1 (L=200)

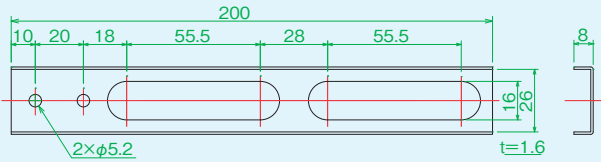

Product name	Slide rail D1 (L=200)
Part code	SLDRD1
Weight	71g
Material	SPCC

Slide rail D2 (L=250)

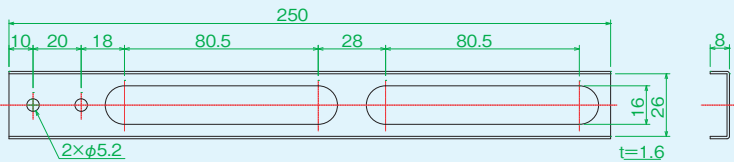

Product name	Slide rail D2 (L=250)
Part code	SLDRD2
Weight	87g
Material	SPCC

Slide rail D3 (L=300)

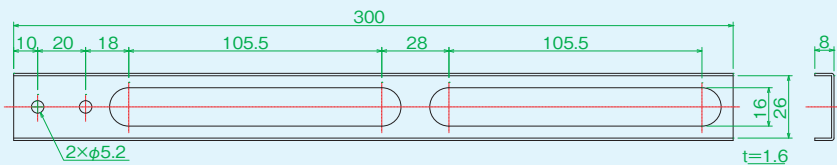

Product name	Slide rail D3 (L=300)
Part code	SLDRD3
Weight	102g
Material	SPCC

Slide rail D4 (L=350)

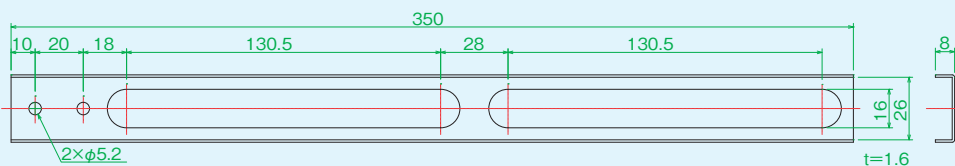

Product name	Slide rail D4 (L=350)
Part code	SLDRD4
Weight	119g
Material	SPCC

Slide rail D5 (L=400)

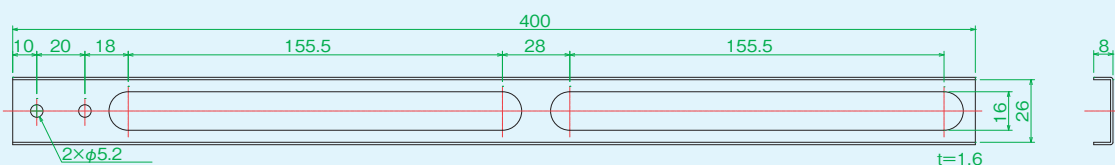

Product name	Slide rail D5 (L=400)
Part code	SLDRD5
Weight	131g
Material	SPCC

Slide rail mounting bracket

Accessories

Mounting bracket for slide rail

Rail mounting bracket (17×17)

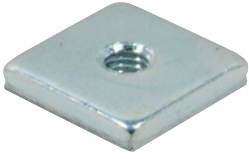

Rail mounting bracket (13×13)

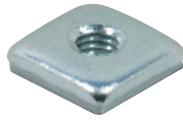

Product name	Rail mounting bracket (17×17)	Rail mounting bracket (13×13)
Part code	SRW-1	SRW-2
Weight	7g	3g
Material	SPCC	SPCC

Rail mounting bracket (17×17)

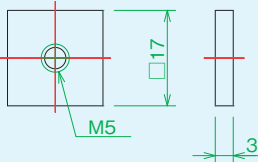

Rail mounting bracket (13×13)

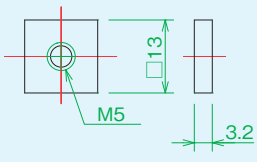

(Usage example)

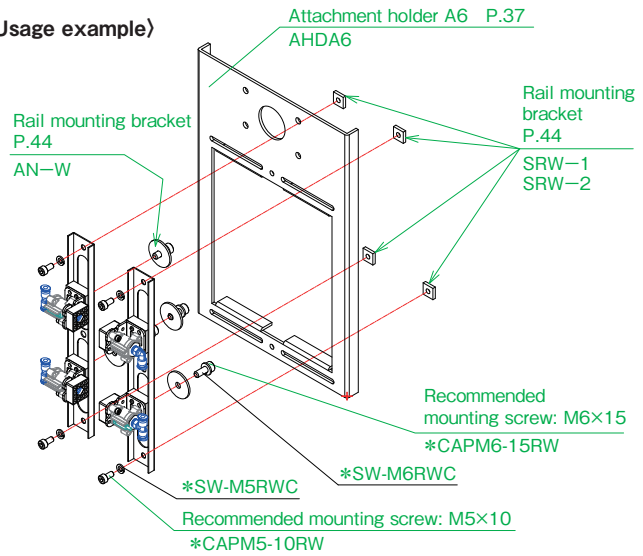

Washer for rail



Product name	Washer for rail
Part code	AN-W
Weight	9g
Material	SPCC

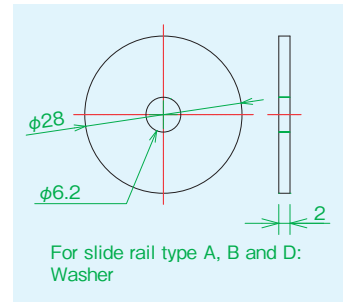

Rail mounting bracket No.4

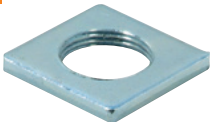

Rail mounting bracket No.5



Rail mounting bracket No.6



Product name	Rail mounting bracketNo.4	Rail mounting bracketNo.5	Rail mounting bracketNo.6
Part code	SRW-4	SRW-5	SRW-6
Weight	10g	9g	15g
Material	SPCC	SPCC	SPCC

Rail mounting bracket No.4

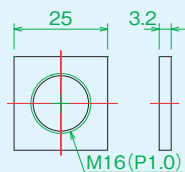

Rail mounting bracketNo.5

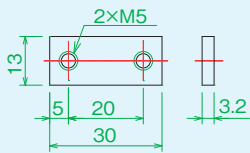

Slide rail:
Mounting bracket for type D
Attachment holder:
Mounting bracket for C3

Rail mounting bracketNo.6

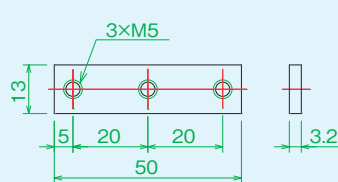

Attachment holder:
Mounting bracket for C1

(Usage example)

