

ペレットタンク
PELLET TANK

MT SERIES

MODEL **MT-5** | **MT-50** | **MT-100** | **MT-200**
MT-25 | **MT-75** | **MT-150**

MT-150

シリーズ名 仕込量 (kg)
Series Name Capacity (kg)



特長 Features

- 5 kg・25kg・50kg・75kg・100kg・150kg・200kgの7タイプ。
- 材料シャッター・ローダー吸い込み口を標準装備。
- キャスター付き。(5 kgタイプ以外)
- 残量確認窓付き。
- Available in 5, 25, 50, 75, 100, 150, and 200kg types
- Standard slide gate and loader intake port
- Standard casters (except 5kg type)
- Material level glass

MT-5

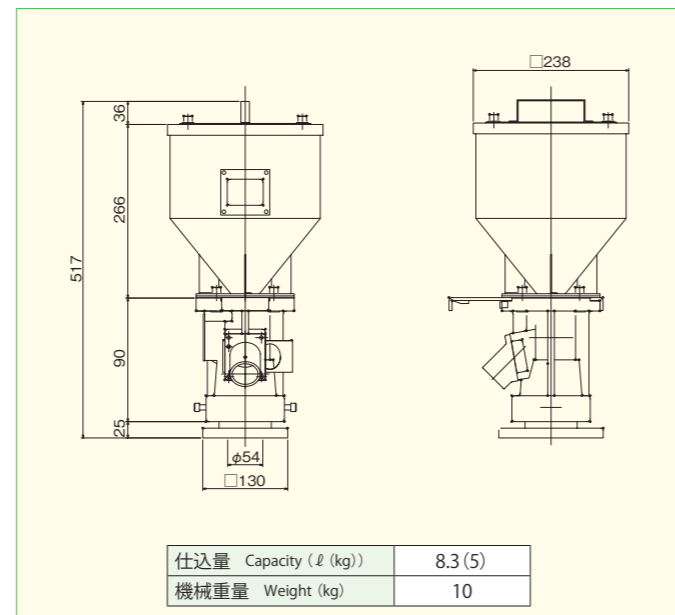

MT-25

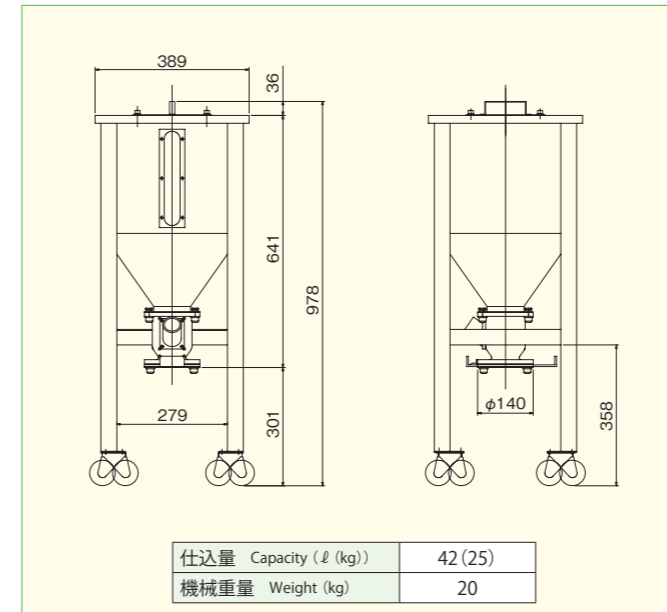

MT-50

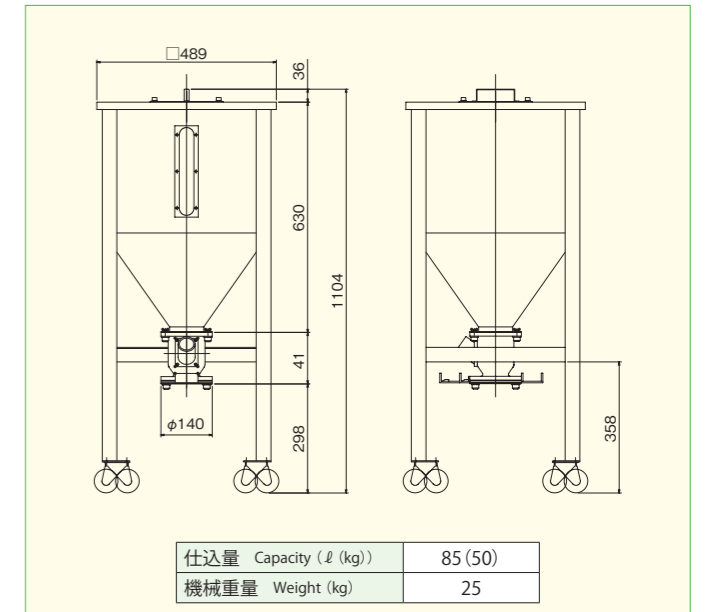

MT-75

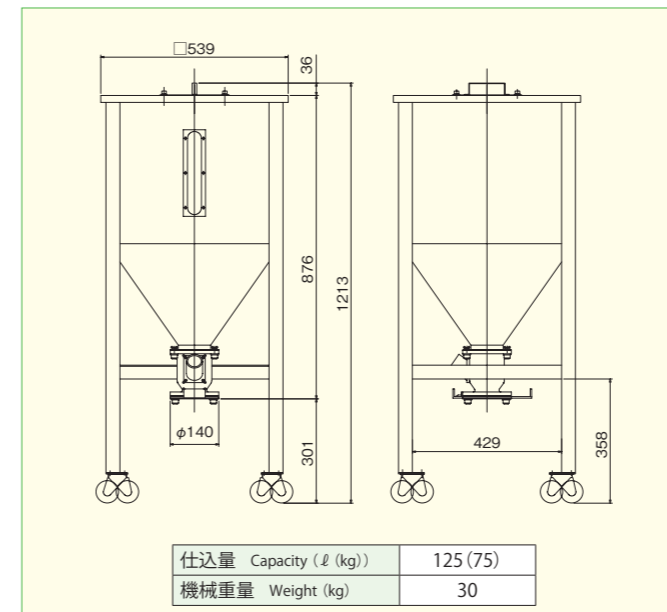

MT-100

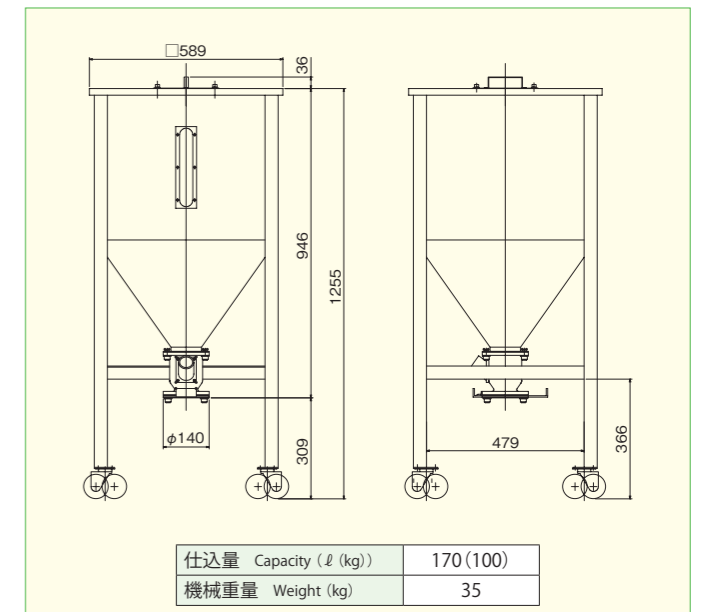

MT-150

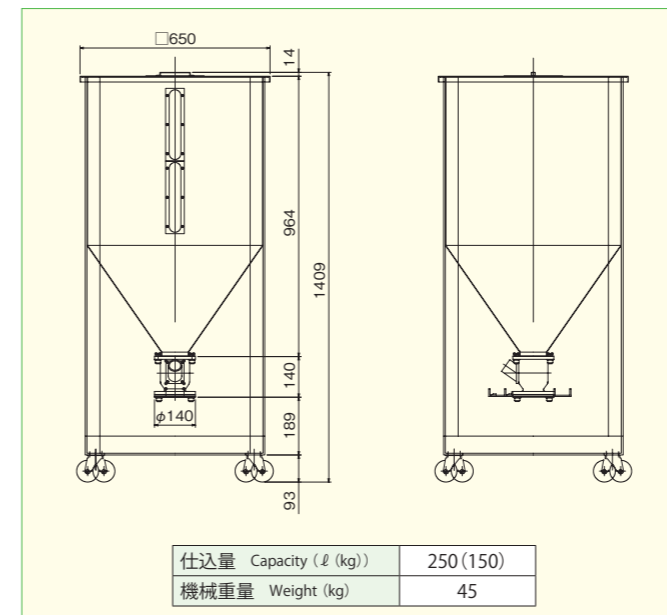

MT-200

